

SELF CLEANING ROTATING SCREENS, the CRDI series with rotating filter cage



Applications

Industry : pump protection for intake water and installation in cooling tower basins, etc
 Agriculture : pump protection and filtration of irrigation water
 WaterTreatment : pump protection and pre-filtration

Working Mode

Installed on the suction side of the pump or on the intake side of a gravity fed system, the Selfcleaning Intake Screens model CRDI cover a flow range of 40 to 630 m³/h. The filter cage is rotating, cleaned and driven by nozzles on a static arm.

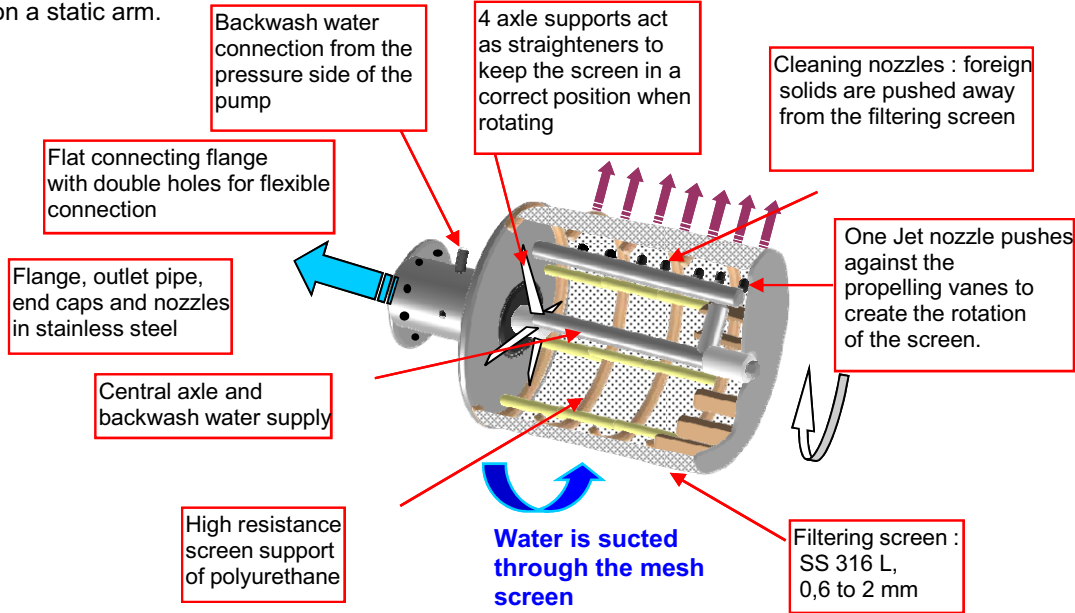

Manufacturing Materials

Standard materials : screen, nozzles, washing arm, central shaft, end caps, driving vanes, body and flanges in **Stainless Steel 304 and 316L**; frame in highly resistant polyurethane and reinforced fiber glass

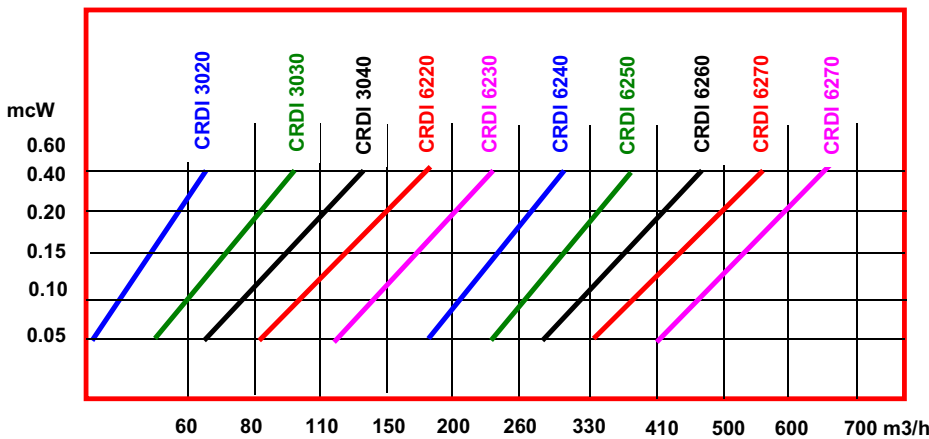

Diagram flow / pressure loss

SELF- CLEANING ROTATING SCREEN, the CRDI series with rotating filter cage



MODEL	Pump suction Flow m3/h		Gravity intake Flow m3/h	
	filtration level		filtration level	
	0,6/mm	1ou2/mm	0,6/mm	1ou2/mm
CRDI 3020-80A	45	65	35	50
CRDI 3030-100A	70	100	55	80
CRDI 3040-150A	95	130	75	105
CRDI 6220-250A	105	150	85	120
CRDI 6230-250A	165	230	130	186
CRDI 6240-250A	220	310	175	250
CRDI 6250-300A	275	390	220	315
CRDI 6260-300A	330	470	265	375
CRDI 6270-350A	385	550	305	440
CRDI 6280-400A	445	630	355	505

MODEL	A	B	C	D BSP F	E BSP M	Backwash		
						pressure at the point E (bar)		Flow m3/h
						mini	maxi	
CRDI 3020-80A	306	445	248	1/4"	3/4"	4	6	6.2
CRDI 3030-100A	306	573	376	1/4"	1"	4	6	7.4
CRDI 3040-150A	306	701	504	1/4"	1"	4.5	6	8.6
CRDI 6220-250A	626	445	248	1/4"	1"1/2"	4.5	6.5	6.2
CRDI 6230-250A	626	573	376	1/4"	1"1/2"	5	6.5	7.4
CRDI 6240-250A	626	701	504	1/4"	1"1/2"	5	6.5	9.3
CRDI 6250-300A	626	829	632	1/4"	2"	5.5	6.5	11.8
CRDI 6260-300A	626	957	760	1/4"	2"	5.5	6.5	13.5
CRDI 6270-350A	626	1085	888	1/4"	2"	5.5	6.5	15.4
CRDI 6280-400A	626	1213	1016	1/4"	2"	5.5	6.5	16.6

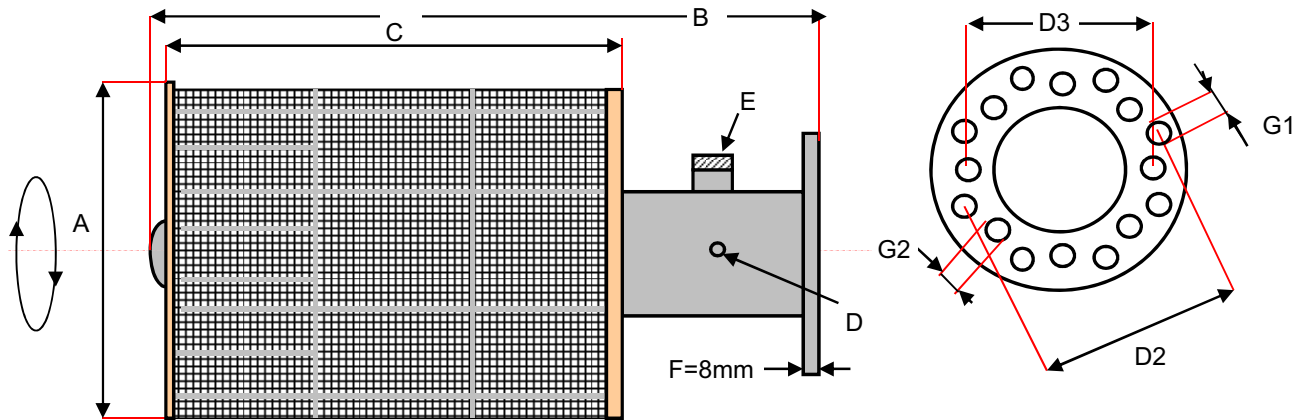

MODEL	Principal Connection DN Nr/holes		D2	Secondary Connection DN Nr/holes		D3	G1	G2	Net Weight kg	Protection Filter 800µ incl.in delivery
	DN	Nr/holes		DN	Nr/holes					
CRDI 3020-80A	80	8	160	65	4	145	18	18	9	1"1/2 MM
CRDI 3030-100A	100	8	180	80	8	160	18	18	10	1"1/2 MM
CRDI 3040-150A	150	8	240	125	8	210	22	18	13	1"1/2 MM
CRDI 6220-250A	250	12	350	200	8	295	22	20	20	1"1/2 MM
CRDI 6230-250A	250	12	350	200	8	295	22	20	21	1"1/2 MM
CRDI 6240-250A	250	12	350	200	8	295	22	20	24	1"1/2 MM
CRDI 6250-300A	300	12	400	250	12	295	22	22	29	2"MM
CRDI 6260-300A	300	12	400	250	12	350	22	22	30	2"MM
CRDI 6270-350A	350	16	460	300	12	400	22	22	32	2"MM
CRDI 6280-400A	400	16	515	350	16	460	24	22	35	2"MM

Given data may be revised without notice.